

**STORMWATER MANAGEMENT FACILITY  
MAINTENANCE AGREEMENT**

This Stormwater Management Facility Maintenance Agreement (hereinafter "Agreement") by and between the City of Manitowoc, Wisconsin, a municipal corporation (the "City"), 900 Quay Street, Manitowoc, Wisconsin 54220-4543 and Lakeshore Mini Storage LLC, P.O. Box 365, Manitowoc WI 54221 (hereinafter "Owner/Developer"). The City together with the Owner/Developer may be referred to individually as a "party" and collectively as the "parties".

**RECITALS**

- A. This Agreement specifically applies to the following parcel located at 2424 Johnston Dr, Manitowoc WI 54221, Parcel No. 808-401-012 described as:

A Parcel of land located in the NE ¼ of the SE ¼ of Section 8, T. 19N., R. 24E., City of Manitowoc, Manitowoc County, Wisconsin, and described as follows:  
Commencing at the east ¼ corner of said Section 8, thence South 89°47'48" West, 33.00 feet along the North line of said SE1/4 to the Westerly right of way line of Johnston Drive being the point of beginning; thence continuing South 89°47'48" West, 700.76 feet; thence South 00°07'19" East, 749.44 feet to the corner of an existing parcel described in Volume 1934, Page 293; thence North 89°47'48" East, 370.91 feet; thence South 00°00'42" West (recorded as South 00°00'35" East), 55.42 feet; thence South 88°36'57" East (recorded as South 88°37'25" East) 110.26 feet along the Southerly line of said existing parcel; thence North 01°15'41" East, 99.25 feet; thence South 88°35'56" East, 80.00 feet; thence North 00°57'20" East, 57.39 feet; thence North 88°50'28" West, 10.00 feet; thence North 01°09'32" East, 53.33 feet; thence South 88°50'28" East, 74.14 feet; thence South 56°31'55" East, 85.22 feet to said Westerly right of way line of Johnston Drive; thence North 00°07'19" West, 649.00 feet to the point of beginning.

- B. The City's Community Development Department(the "Department") & the Planning Commission approved a site plan for the Owner/Developer pursuant to Section 15.370(2) of the City's Municipal Code for the Property; said site plan is hereinafter identified as SP1-2021 which was approved by the City on February 4, 2021.

NOW, THEREFORE, in consideration of the Recitals and the mutual promises herein made and for other good and valuable consideration, the receipt and sufficiency of which the parties hereby acknowledge, the Owner/Developers and the City agree as follows:

1. Recitals. The Recitals are deemed to be true and correct.
2. Owner/Developer Responsibilities. The Owner/Developer jointly and severally guarantee to the City that they will perform the following related to the Site Plan:
  - A. The Owner/Developer shall be responsible for the routine and extraordinary maintenance of the stormwater facilities located on the Property which includes, but is not limited to, one **Stormwater Mechanical Separator** and other appurtenant facilities designed to treat stormwater, or collect, channel, hold, inhibit or divert the movement of stormwater through and from the Property. Said stormwater facilities are hereinafter collectively referred to as the "Facility" identified in Exhibit "A", Owner/Developer shall perform all stormwater management practices identified in

Exhibit "B"; said Exhibits "A" and "B" are attached and incorporated herein by reference.

- B. The Facility is for the benefit of the Owner/Developer, and the Owner/Developer shall maintain and inspect the Facility and all appurtenances related thereto as required under Exhibit "B" and shall comply with a maintenance plan which is on file in the City's Engineering Department. The City Engineering Department shall be defined herein as the City Engineer or designee as its authorized representative.
  - C. The Owner/Developer shall submit to the City Engineering Department an annual Facility inspection report for each and every calendar year (hereinafter "calendar year" is defined as October 1st through and including the following September 30th) beginning with the calendar year after which the Facility has been placed in service and approved by the City. The report shall be filed with the City's Engineering Department on or before October 1st of each calendar year and shall be in form and content as required by the City. For example, if the Facility was placed in service in calendar year 2021 the first inspection report shall be due on or before October 1, 2022.
  - D. The City or its designee is authorized by the Owner/Developer to access the Owner/Developer property, as necessary, to conduct inspections of the Facility to ascertain compliance with this Agreement.
  - E. Upon the City providing written notification to the Owner/Developer of a problem with the Facility that requires correction, the specified corrective action(s) shall be performed by the Owner/Developer within a reasonable time frame as set forth in writing by the City Engineering Department.
  - F. The City is authorized to perform the corrective action(s) identified under E. above if the Owner/Developer does not make the required corrections, or if such corrections are not implemented to the City's sole satisfaction, within a reasonable time period specified in writing by the City Engineering Department. The cost and expense of such corrections shall be expressly borne by the Owner/Developer. The City may enter such costs on the tax roll against the Property as a special assessment, which shall be paid with other taxes levied thereupon for the calendar year in which the City completed the required corrections.
  - G. The City retains the express right to stop work performed by the Owner/Developer at the Facility, and to amend or alter such work being undertaken by the Owner/Developers.
3. Best Management Practices (BMP). The Owner/Developer agrees to follow the State of Wisconsin Department of Natural Resources Technical Standards for erosion and sediment control and post-construction storm water management at the Facility. Owner/Developer shall comply with the standards and guidelines of the Wisconsin Department of Natural Resource (WDNR) and shall comply with any additional requirements as required by City regulation or by the City Engineering Department.
4. Representations. All representations and warranties of the Owner/Developer and the City set forth in this Agreement and in all agreements expressly referred to herein, shall at all times be true, complete and correct.

5. Obligation to Maintain and Repair. The Owner/Developer, shall, during the term of this Agreement, keep and maintain the Facility in good repair and working order, and will make or cause to be made from time to time all necessary repairs thereto, and renewals and replacements thereof so as to maintain a fully operational Facility that functions to control and manage stormwater related to the Property. Facility maintenance responsibilities are detailed in Exhibit "B".
6. Insurance. During the term of this Agreement, the Owner/Developer shall continually maintain in effect, insurance against such risks, both generally and specifically with respect to the Facility, as are customarily insured against improvements of like size and character including at least, but not limited to, Commercial General Liability Insurance, including Blanket Contractual Liability Insurance, against liability for personal injury, including the death of persons resulting from injuries occurring on or in any way related to the Facility, in the minimum amount of Five Hundred Thousand (\$500,000) Dollars per occurrence and against liability for damage to the Property occurring on, or in, or relating in any way to the Facility in the minimum amount of Five Hundred Thousand (\$500,000) Dollars per occurrence.

All insurance policies shall be purchased and maintained with insurance companies authorized to do business in the State of Wisconsin. Certificates and endorsements of all such insurance shall be filed with the City Clerk's office, with the City named as an additional insured, and shall further be subject to the review and approval of the City Attorney. Copies of said policies, certificates and endorsements listing the City as an additional insured shall be provided to the City Engineering Department within fourteen (14) consecutive calendar days after the Owner/Developer executes this Agreement. Each such policy of insurance shall contain a provision that the insurance company shall give the City at least thirty (30) consecutive calendar days prior written notice of cancellation, nonrenewal or material change during the term of this Agreement (or if the insurance company is unable or unwilling to provide such notification, the Owner/Developer shall provide said notice). In the event of a proposed cancellation or nonrenewal of any such policy by an insurance company, the Owner/Developer shall secure adequate replacement insurance policies prior to the effective date of such cancellation or non-renewal.

7. Claims and License, Injury and Property Damage. During the term of this Agreement, and to the extent covered by the Insurance required by Section 6 above, the Owner agrees to protect, defend, indemnify and hold the City, its officers, agents and employees free and harmless from and against any and all claims of third parties which result in losses, penalties, damages, settlements, costs, charges, professional fees, attorney's fee, or other expenses or liabilities in connection with or arising directly or indirectly out of Owner's obligations under this Agreement. In no event shall the Owner or its insurer be liable for or have any indemnification obligations for any losses, damages, costs, fees, expenses, etc. arising out of the City's negligence or failure to perform its obligations under this Agreement. The Owner further agrees that the City will, if the City and the Owner mutually deem it appropriate, provide any additional defense to any claim hereunder, the full costs of which shall be borne by the Owner. Furthermore, if a third party shall make claim against the City related to the Facility, the Owner at its sole option, shall have the right to participate in, or assume the defense of any such claim, provided however, the

City shall remain liable for all costs including attorney fees, to the extent of the City's negligence or failure to perform its obligations

8. **Notice and Right to Cure.** A material default or material breach (whether material default or material breach, hereinafter referred to as a "breach") of this Agreement shall be defined as the failure of the parties to perform any material term, covenant, condition, warranty or promise of this Agreement required to be performed by the Owner/Developer or the City. In the event of any breach of this Agreement or any of its terms or conditions by any party hereto, the non-breaching party shall deliver written notice to the breaching party detailing the breach, and such non-breaching party shall, upon written notice from the other, proceed immediately to cure or remedy such breach, and in any event shall cure any such default or breach within thirty (30) consecutive calendar days of the receipt of such notice, if such breach is of a nature that can be reasonably cured within such thirty (30) day period. If such breach is of a nature that cannot be reasonably cured within such thirty (30) day period, such party shall have commenced such cure and shall be diligently pursuing the same. In the case such action is not taken or is not diligently pursued, the aggrieved party(ies) may have available the remedies provided for herein, however, it is expressly agreed that a breach of this Agreement shall not entitle the Owner/Developer to terminate this Agreement.
9. **Additional Remedies.** In the event of any breach of this Agreement which has not been cured in accordance with Section 8, the non-breaching party (ies) may utilize any remedies the parties may have at law or in equity. In the event that any party shall breach any of its obligations under this Agreement and shall not cure or remedy such breach, or commence to diligently pursue the same as provided in Section 8, and following notice as provided above, then the non-breaching party(ies) shall have the right to institute any other actions or proceedings as it may have available at law or equity if it deems desirable for effectuating the purposes of this Agreement, provided that any delay by the non-breaching party(ies) in instituting or prosecuting any such action or proceedings or otherwise asserting its rights under this section shall not operate as a waiver of such rights or to deprive it of, or, to limit such rights in any way (it being the intent of this provisions that the non-breaching party(ies) should not be constrained, so as to avoid the risk of being deprived of, or limited in the exercise of the remedy provided in this section because of concept of waiver, laches or otherwise, to exercise such remedy at a time when it may still hope otherwise to resolve the breach created by the default involved); nor shall any waiver in fact made by the non-breaching party(ies) with respect to any specific default by the other party under this section be considered or treated as the waiver of the rights of the non-breaching party(ies) with respect to any other defaults by the other party under this section, or with respect to the particular default except to the extent specifically waived in writing.
10. **Rights and Remedies Cumulative.** The rights and remedies of the Owner/Developer and the City, whether provided at law or in equity or by this Agreement, shall be cumulative, and the exercise of anyone (1) or more of such remedies shall not preclude the exercise at the same or different times of any other such remedies for the same event of breach or of any remedies for any other event of breach by the other parties. No waiver made by any party with respect to the performance or manner or time of any obligation of any party under the Agreement, shall be considered a waiver of any rights of the Owner/Developer or the City (as the case may be) to enforce any other obligations of the parties under this Agreement. A delay of any party in the enforcement of any term, covenant, condition,

warranty or promise contained in this Agreement shall not be construed as a waiver of any party's right to enforce said obligations.

11. **Continuing Obligations.** The obligations of each of the parties shall continue until such time as this Agreement is terminated in writing by the Owner/Developer and the City.
12. **Termination.** This Agreement shall terminate, and become immediately null and void, upon the date of execution of a written instrument releasing the Owner/Developer and the City from all obligations hereunder.
13. **Approvals in Writing.** Whenever under this Agreement approvals, authorizations, determinations, satisfactions or waivers are authorized or required, such approvals, authorizations, determinations, satisfactions or waivers shall be effective and valid only when given in writing, signed by the duly authorized officer of the City, and delivered to the party to whom it is directed at the address specified in Section 15. Wherever any approval is required by the terms of this Agreement, and request or application for such approval is duly made, such approval shall not be unreasonably withheld.
14. **Inspection of Records.** The City shall have the right to inspect any and all records, contracts, financial statements, ledgers or written documents which relate to and are generated by the responsibilities and obligations of the Owner/Developer under the terms of this Agreement, and which are related to verification or documentation of the activities or actions related to the Facility. This right of inspection shall apply to not only those records and documents that are within the physical control and custody of the Owner/Developer, but the Owner/Developer shall also provide copies of any contracts, agreements or other documents with third parties if so, requested by the City, that are necessary to verify or document the operation of the Facility.
15. **Notices and Demands.** A notice, demand or other communication under this Agreement by any party to any other party shall be sufficiently given or delivered if it is dispatched by facsimile transmission, or by first class mail, or by registered or certified mail, postage prepaid, return receipt requested, or delivered personally as set forth below:

**Owner/Developer:** Lakeshore Mini Storage LLC  
Attn: Scott Mertens  
P.O. Box 365  
Manitowoc WI, 54220

**City:** City of Manitowoc  
Attn: City Clerk  
900 Quay Street  
Manitowoc WI 54220-4543

with a copy to: City Engineer  
City of Manitowoc  
900 Quay Street  
Manitowoc WI 54220-4543

The above addresses may be changed at any time by the parties by notice given in the manner provided above.

The parties further agree that electronically reproduced signatures such as by facsimile transmission are valid for execution or amendment of this Agreement, and that electronic transmission/facsimile is an authorized form of notice as that term is used in this Agreement.

16. **No Liability of the City.** The City shall have no obligation or liability to any lender, architect, engineer, contractor, or subcontractors, or any other party retained by the Owner/Developer in the performance of the Owner/Developer obligations and responsibility under the terms and conditions of this Agreement. Each party specifically agrees that no representations, statements, assurances, or guaranty will be made by such party to any third party or by any third party which is contrary to the provisions of this Agreement.
17. **Severability.** If any provisions of this Agreement are deemed by a court of competent jurisdiction to be invalid or unenforceable, the remainder of this Agreement or the application of such term or provision to parties or circumstances, other than those as to which it is invalid or unenforceable, shall not be affected thereby, and each term and provision of this Agreement shall be valid and shall be enforced to the extent permitted by law.
18. **Amendments.** This Agreement is the entire agreement between the parties and can only be modified or changed in writing executed by all parties.
19. **Successors and Assigns.** This Agreement shall be binding upon and inure to the benefit of the parties hereto, as well as their respective successors, heirs, transferees and assigns. Any transfer of any party's interest under this Agreement shall not release the transferor from his or its obligations hereunder.
20. **Recordation.** This Agreement or at the City's sole option, a Memorandum of Agreement, and any subsequent modifications thereof or additions thereto shall be, upon being duly executed, recorded by the City at the Owner/Developer sole expense, at the Register of Deeds for Manitowoc County, Wisconsin, and shall be deemed to be and interpreted as a covenant running with the Property. The City shall, upon the party's agreement to terminate this Agreement, file and record at the Owner/Developer expense an instrument(s) at the Register of Deeds for Manitowoc County terminating the Agreement.
21. **Time of Essence.** Time is of the essence as to this Agreement and of every term, covenant, condition, warranty or promise to be performed by the parties.
22. **Assignment.** The Owner/Developer shall not assign this Agreement or any part of it, without the prior written consent of the City, which consent shall not be unreasonably withheld.
23. **Applicable Law.** This Agreement shall be deemed to have been made in Manitowoc County, Wisconsin, and shall be governed by, construed under, and enforced in accordance with, the law of the State of Wisconsin, except as otherwise provided herein. All actions or proceedings relating directly or indirectly to this Agreement, whether sounding in contract or tort, shall be litigated only in the circuit court located in

Manitowoc County, Wisconsin. All parties to this Agreement hereby subject themselves to the jurisdiction of the circuit court for Manitowoc County, Wisconsin.

24. **Headings.** The section titles have been inserted in this Agreement primarily for convenience, and do not define, limit or construe the contents of such paragraphs. If headings conflict with the text, the text shall control.
25. **Pronouns.** Pronouns in this Agreement (including, but not limited to, those referring to the Owner/Developer and the City), importing any specific gender shall be interpreted to refer to limited liability companies, corporations, partnerships, men and women, as the identity of the parties hereto, or the parties herein referred to, may require. Pronouns, verbs, and/or other words in this Agreement importing the singular number shall be interpreted as plural and plural words as singular, as the identity of the parties hereto, or the parties or objects herein referred to, may require.
26. **Integration and Conflicts.** This Agreement and any special terms and conditions appended hereto at the time of execution of this Agreement, shall constitute the entire, integrated agreement of the parties hereto with respect to the matters addressed herein. This Agreement, and each and every term and condition, may be added to or amended only by the mutual written agreement of the parties as permitted in Section 18, which amendment or modification shall be executed with the same formalities as this Agreement shall have been executed. Special terms and conditions, if any, which are agreed upon by the parties hereto at the time this Agreement is executed, shall be reduced to writing in accordance with Section 13.

If the provisions of any deed, lease, agreement, contract, note, mortgage, security agreement, Site Plans or other document between the parties hereto conflicts with the provisions of this Agreement, the provisions of this Agreement shall control.
27. **Relationship of Parties.** Nothing in this Agreement nor any act of the Owner/Developer or the City shall be deemed or construed to create any relationship of third-party beneficiary, of principal or agent, of limited or general partners, of joint venture, or of any association whatsoever between the parties hereto.
28. **Survival of Warranties, Representations and Agreements.** Any warranty, representation or agreement herein contained shall survive the date of this Agreement.
29. **Construction.** All parties have contributed to the drafting of this Agreement. In the event of a controversy, dispute or contest over the meaning, interpretation, validity or enforceability of this Agreement or any of its terms or conditions, there shall be no inference, presumption or conclusion drawn whatsoever against any party hereunder by virtue of that party having drafted this Agreement or any portion thereof.
30. **Creation of New Tracts of Land from Owner/Developer Property.** Unless so directed by the City, on or after the effective date of this Agreement, any land divisions creating new parcels that directly affect the or any developments occurring on these same lands under a lease or similar arrangement, and which shall be designed to drain stormwater to the Facility, shall be required to enter into an amendment to this Agreement or a similar agreement with the City on terms and conditions substantially the same as those included in this Agreement.

31. **Counterparts.** This Agreement may be executed in counterpart originals, each of which when duly executed and delivered shall be deemed an original and all of which when taken together shall constitute one instrument.
32. **Date.** This Agreement shall be dated and effective and binding as of the date of the last execution.

This instrument was drafted by: Paul Steinbrecher, SMI, Inc. 4/7/21

File: \Erosionstorm\Maintenance Agreements Manitowoc\2021 Lakeshore Mini Storage\Maintenance Agreement.doc





**Exhibit A - Location Map**  
**Storm Water Management Practices Covered by this Agreement**

The storm water management practices covered by this Agreement are depicted in the reduced copy of the construction plans, as shown below. The practices include one (1) stormwater Mechanical treatment unit located in a Parcel of land located in the NE ¼ of the SE ¼ of Section 8, T. 19N., R. 24E., City of Manitowoc, Manitowoc County, Wisconsin.



## **Exhibit B**

### **Minimum Storm Water Practice Maintenance Requirements**

This exhibit explains the basic function of each of the storm water practices listed in Exhibit A and prescribes the minimum maintenance requirements to remain compliant with this Agreement. The maintenance activities listed below are aimed to ensure these practices continue serving their intended functions in perpetuity. The list of activities is not all inclusive, but rather indicates the minimum type of maintenance that can be expected for this particular site. Access to the stormwater practices for maintenance vehicles is shown in Exhibit A. Any failure of a storm water practice that is caused by a lack of maintenance will subject the responsible party to enforcement of the provisions listed in this Agreement by the City of Manitowoc.

#### **System Description:**

For details on the Stormwater Mechanical Treatment Unit and a complete list of Maintenance responsibilities see the Stormwater Management Plan and the Erosion Control Plan for Lakeshore Mini Storage on file at the City of Manitowoc Engineering Office.

#### **Stormwater Mechanical Treatment Unit Details:**

I:\COMMON\CONTR\TREATM\1 CASCADE\3 STANDARD DRAWINGS\DWG-CS-4.DWG 1/22/2010 9:34 AM

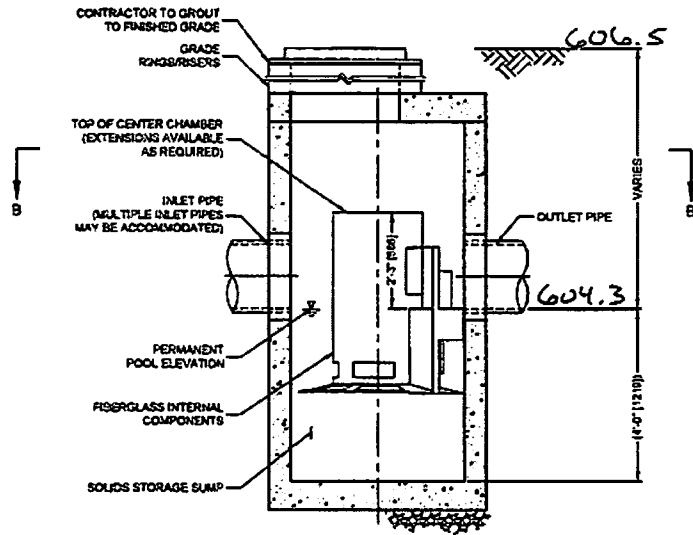
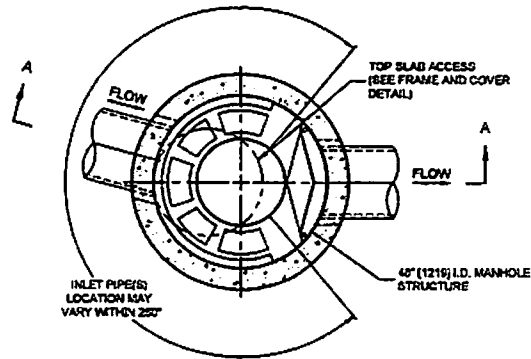

**CASCADE separator™**

**CASCADE SEPARATOR DESIGN NOTES**

THE STANDARD CS-4 CONFIGURATION IS SHOWN. ALTERNATE CONFIGURATIONS ARE AVAILABLE AND ARE LISTED BELOW. SOME CONFIGURATIONS MAY BE COMBINED TO SUIT SITE REQUIREMENTS.

**CONFIGURATION DESCRIPTION**

- GRATED INLET ONLY (NO INLET PIPE)
- GRATED INLET WITH INLET PIPE OR PIPES
- CURB INLET ONLY (NO INLET PIPE)
- CURB INLET WITH INLET PIPE OR PIPES

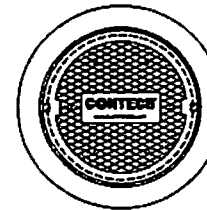

**FRAME AND COVER**  
(DIAMETER VARIES)  
NOT TO SCALE

**SITE SPECIFIC DATA REQUIREMENTS**

STRUCTURE ID	
WATER QUALITY FLOW RATE (cfs [L/s])	
PEAK FLOW RATE (cfs [L/s])	
RETURN PERIOD OF PEAK FLOW (yr)	
RIM ELEVATION	
PIPE DATA	INVERT MATERIAL DIAMETER
INLET PIPE 1	
INLET PIPE 2	
OUTLET PIPE	

NOTES / SPECIAL REQUIREMENTS

**GENERAL NOTES**

1. CONTECH TO PROVIDE ALL MATERIALS UNLESS NOTED OTHERWISE.
2. FOR SITE SPECIFIC DRAWINGS WITH DETAILED STRUCTURE DIMENSIONS AND WEIGHT, PLEASE CONTACT YOUR CONTECH ENGINEERED SOLUTIONS LLC REPRESENTATIVE, [www.contechES.com](http://www.contechES.com)
3. CASCADE SEPARATOR WATER QUALITY STRUCTURE SHALL BE IN ACCORDANCE WITH ALL DESIGN DATA AND INFORMATION CONTAINED IN THIS DRAWING. CONTRACTOR TO CONFIRM STRUCTURE MEETS REQUIREMENTS OF PROJECT.
4. CASCADE SEPARATOR STRUCTURE SHALL MEET AASHTO HS20 LOAD RATING, ASSUMING EARTH COVER OF 0' - 2' (0.15), AND GROUNDWATER ELEVATION AT, OR BELOW, THE OUTLET PIPE INVERT ELEVATION. ENGINEER OF RECORD TO CONFIRM ACTUAL GROUNDWATER ELEVATION. CASTINGS SHALL MEET AASHTO M208 AND BE CAST WITH THE CONTECH LOGO.
5. CASCADE SEPARATOR STRUCTURE SHALL BE PRECAST CONCRETE CONFORMING TO ASTM C478 AND AASHTO LOAD FACTOR DESIGN METHOD.
6. ALTERNATE UNITS ARE SHOWN IN MILLIMETERS (mm).

**INSTALLATION NOTES**

- A. ANY SUB-BASE, BACKFILL DEPTH, AND/OR ANTI-FLOTATION PROVISIONS ARE SITE-SPECIFIC DESIGN CONSIDERATIONS AND SHALL BE SPECIFIED BY ENGINEER OF RECORD.
- B. CONTRACTOR TO PROVIDE EQUIPMENT WITH SUFFICIENT LIFTING AND REACH CAPACITY TO LIFT AND SET THE CASCADE SEPARATOR MANHOLE STRUCTURE.
- C. CONTRACTOR TO INSTALL JOINT SEALANT BETWEEN ALL STRUCTURE SECTIONS AND ASSEMBLE STRUCTURE.
- D. CONTRACTOR TO PROVIDE, INSTALL, AND GROUT INLET AND OUTLET PIPE(S). MATCH PIPE INVERTS WITH ELEVATIONS SHOWN. ALL PIPE CENTERLINES TO MATCH PIPE OPENING CENTERLINES.
- E. CONTRACTOR TO TAKE APPROPRIATE MEASURES TO ASSURE UNIT IS WATER TIGHT, HOLDING WATER TO FLOODLINE INVERT MINIMUM. IT IS SUGGESTED THAT ALL JOINTS BELOW PIPE INVERTS ARE GROUTED.

**CONTECH**  
ENGINEERED SOLUTIONS LLC

[www.contechES.com](http://www.contechES.com)  
2025 Carter Pointe Dr., Suite 400, West Chester, OH 45380  
937-335-1122 937-563-7000 937-563-7993 FAX

**CS-4  
CASCADE SEPARATOR  
STANDARD DETAIL**

## Cascade Separator® Inspection and Maintenance Guide

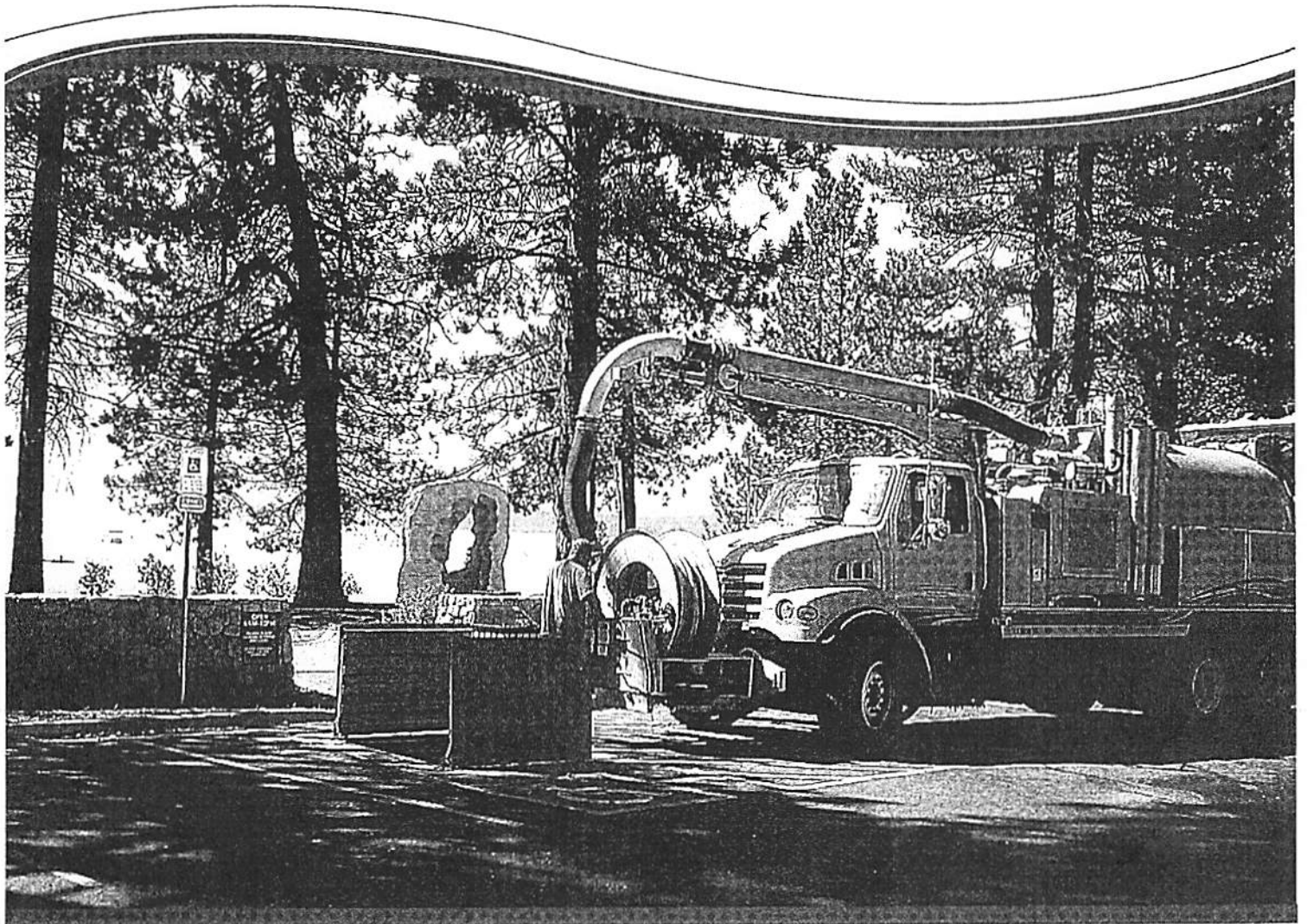

CASCADE  
separator®

## Maintenance

The Cascade Separator\* system should be inspected at regular intervals and maintained when necessary to ensure optimum performance. The rate at which the system collects sediment and debris will depend upon on-site activities and site pollutant characteristics. For example, unstable soils or heavy winter sanding will cause the sediment storage sump to fill more quickly but regular sweeping of paved surfaces will slow accumulation.

## Inspection

Inspection is the key to effective maintenance and is easily performed. Pollutant transport and deposition may vary from year to year and regular inspections will help ensure that the system is cleaned out at the appropriate time. At a minimum, inspections should be performed twice per year (i.e. spring and fall). However, more frequent inspections may be necessary in climates where winter sanding operations may lead to rapid accumulations, or in equipment wash-down areas. Installations should also be inspected more frequently where excessive amounts of trash are expected.

A visual inspection should ascertain that the system components are in working order and that there are no blockages or obstructions in the inlet chamber, flumes or outlet channel. The inspection should also quantify the accumulation of hydrocarbons, trash and sediment in the system. Measuring pollutant accumulation can be done with a calibrated dipstick, tape measure or other measuring instrument. If absorbent material is used for enhanced removal of hydrocarbons, the level of discoloration of the sorbent material should also be identified during inspection. It is useful and often required as part of an operating permit to keep a record of each inspection. A simple form for doing so is provided in this Inspection and Maintenance Guide.

Access to the Cascade Separator unit is typically achieved through one manhole access cover. The opening allows for inspection and cleanout of the center chamber (cylinder) and sediment storage sump, as well as inspection of the inlet chamber and slanted skirt. For large units, multiple manhole covers allow access to the chambers and sump.

The Cascade Separator system should be cleaned before the level of sediment in the sump reaches the maximum sediment depth and/or when an appreciable level of hydrocarbons and trash has accumulated. If sorbent material is used, it must be replaced when significant discoloration has occurred. Performance may be impacted when maximum sediment storage capacity is exceeded. Contech recommends maintaining the system when sediment level reaches 50% of maximum storage volume. The level of sediment is easily determined by measuring the distance from the system outlet invert (standing water level) to the top of the sediment pile. To avoid underestimating the level of sediment in the chamber, the measuring device must be lowered to the top of the sediment pile carefully. Finer, silty particles at the top of the pile typically offer less resistance to the end of the rod than larger particles toward the bottom of the pile. Once this measurement is recorded, it should be compared to the chart in this document to determine if the height of the sediment pile off the bottom of the sump floor exceeds 50% of the maximum sediment storage.

## Cleaning

Cleaning of a Cascade Separator system should be done during dry weather conditions when no flow is entering the system. The use of a vacuum truck is generally the most effective and convenient method of removing pollutants from the system. Simply remove the manhole cover and insert the vacuum tube down through the center chamber and into the sump. The system should be completely drained down and the sump fully evacuated of sediment. The areas outside the center chamber and the slanted skirt should also be washed off if pollutant build-up exists in these areas.

In installations where the risk of petroleum spills is small, liquid contaminants may not accumulate as quickly as sediment. However, the system should be cleaned out immediately in the event of an oil or gasoline spill. Motor oil and other hydrocarbons that accumulate on a more routine basis should be removed when an appreciable layer has been captured. To remove these pollutants, it may be preferable to use absorbent pads since they are usually less expensive to dispose than the oil/water emulsion that may be created by vacuuming the oily layer. Trash and debris can be netted out to separate it from the other pollutants. Then the system should be power washed to ensure it is free of trash and debris.

Manhole covers should be securely seated following cleaning activities to prevent leakage of runoff into the system from above and to ensure proper safety precautions. Confined space entry procedures need to be followed if physical access is required. Disposal of all material removed from the Cascade Separator system must be done in accordance with local regulations. In many locations, disposal of evacuated sediments may be handled in the same manner as disposal of sediments removed from catch basins or deep sump manholes. Check your local regulations for specific requirements on disposal. If any components are damaged, replacement parts can be ordered from the manufacturer.

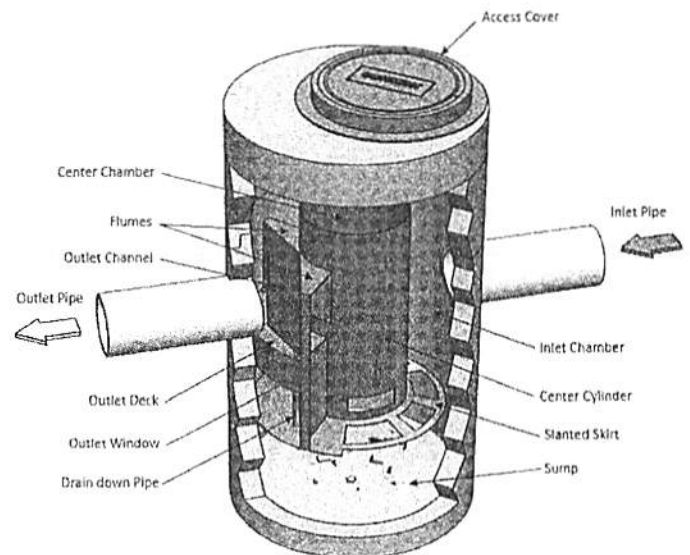

## Cascade Separator® Maintenance Indicators and Sediment Storage Capacities

Model Number	Diameter		Distance from Water Surface to Top of Sediment Pile		Sediment Storage Capacity	
	ft	m	ft	m	y <sup>3</sup>	m <sup>3</sup>
CS-3	3	0.9	1.5	0.5	0.4	0.3
CS-4	4	1.2	1.5	0.5	0.7	0.5
CS-5	5	1.3	1.5	0.5	1.1	0.8
CS-6	6	1.8	1.5	0.5	1.6	1.2
CS-8	8	2.4	1.5	0.5	2.8	2.1
CS-10	10	3.0	1.5	0.5	4.4	3.3
CS-12	12	3.6	1.5	0.5	6.3	4.8

Note: The information in the chart is for standard units. Units may have been designed with non-standard sediment storage depth.



A Cascade Separator unit can be easily cleaned in less than 30 minutes.

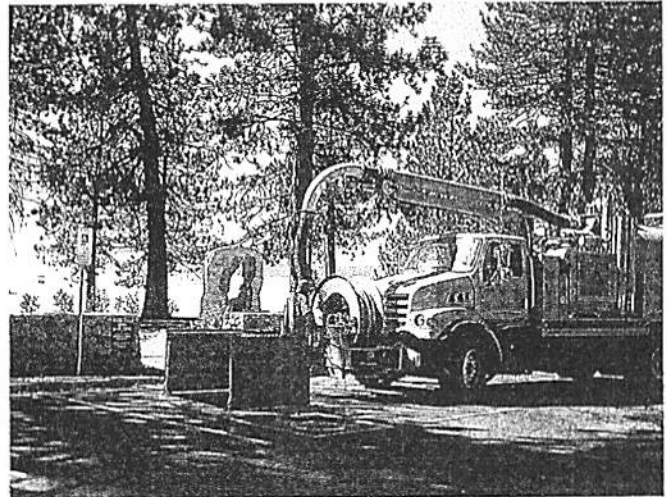

A vacuum truck excavates pollutants from the systems.



